

FMS Secondary Cleaner

Reliable Cleaning at an Affordable Price

The FMS Secondary Belt Cleaner features carbide blades, self-adjusting spring tensioners and unique cushions that independently tension each blade to the belt. This simple but durable design provides quality cleaning performance at an affordable price.

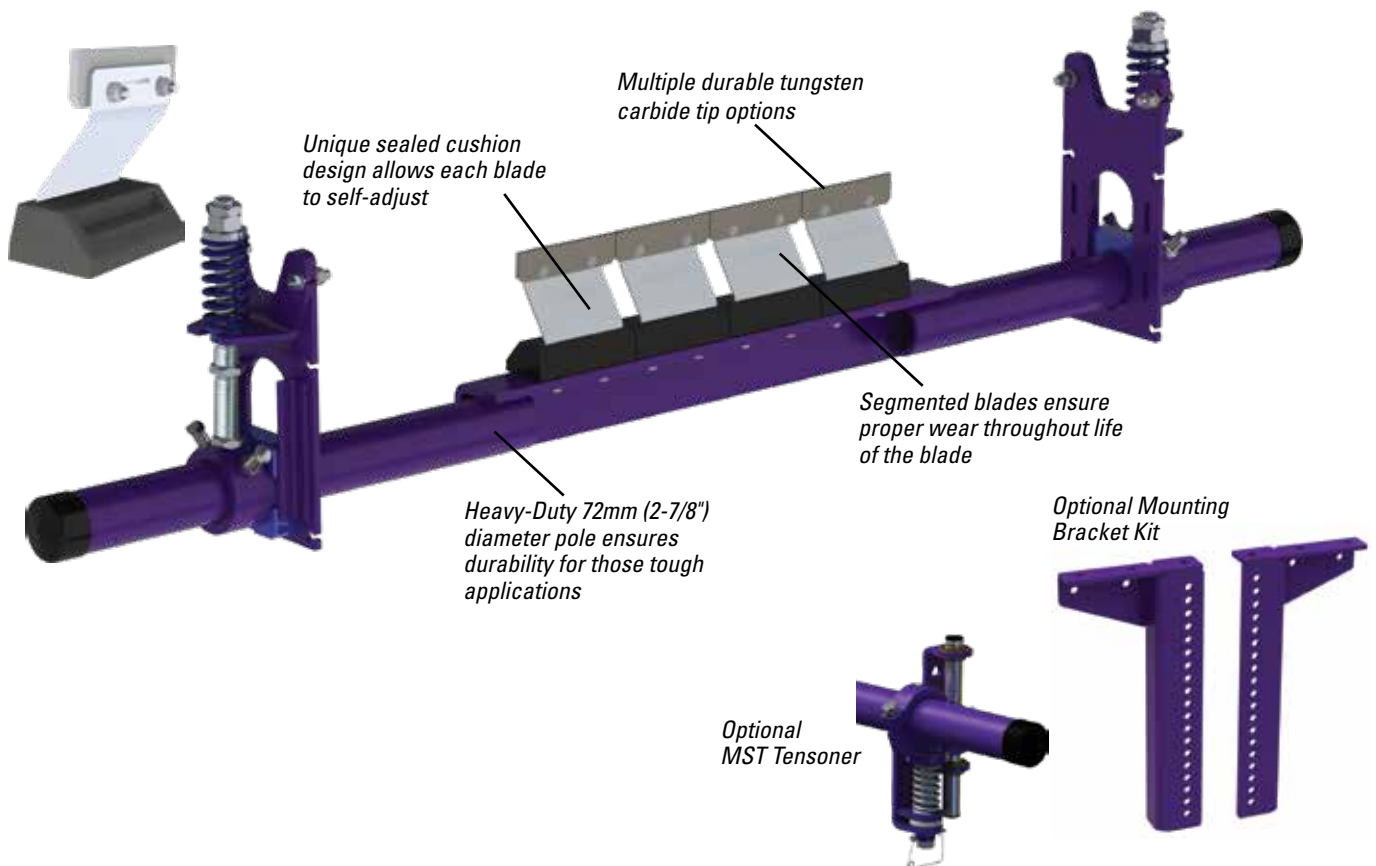

Features and Benefits

- **Made for mining conveyors.** Made from heavy-duty steel with corrosion-resistant powder coating, the FMS is available in sizes for belt widths from 450 to 1800mm (18" to 72"). Additional sizes are available upon request.
- **For belt speeds up to 5 m/s (1000 fpm).**
- **Compact spring tensioner.** Utilizes the spring tensioner to maintain constant pressure on the belt.
- **Cleaning efficiency of metal blades.** The thin, hard edges of the 150mm (6") wide metal blades deliver high cleaning efficiency and long wear life.
- **Works with Flexco mechanical splices.** The C-Tip tungsten carbide blades are impact-resistant, and the spring cushion allows them to move away from a passing splice without damage and with minimal cleaning disruption.
- **A complete cleaning system.** When the FMS is teamed with the MSP or MMP Precleaner the system provides excellent cleaning power for tough applications.

FMS

Secondary Cleaner

Specifications and Guidelines

Maximum Belt Speed

5 m/s (1000 FPM)

Temperature Rating

-35° C to 148° C (-30° F to 300° F)

Usable Blade Wear Length

9 mm (3/8")

Available for Belt Widths

450 to 1800 mm (18" to 72")

Blade Material

Impact resistant, long-lasting tungsten carbide (C-Tips for mechanical fasteners, V-Tips for vulcanized belts)

CEMA Cleaner Rating

Class 4

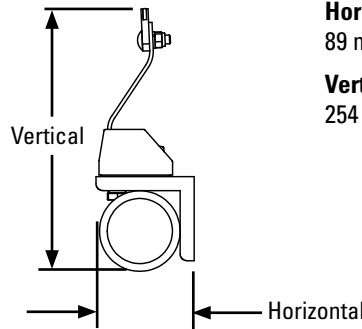

Horizontal Clearance Required

89 mm (3-1/2")

Vertical Clearance Required

254 mm (10")

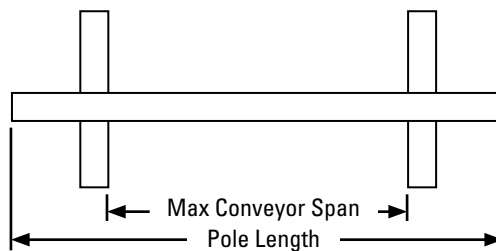

Pole Length

Belt width + 1350 mm (54")

Maximum Conveyor Span

Belt width + 1100 mm (44")

Ordering Information

FMS Secondary with YST Tensioner and C-Tips			
Belt Width		Complete Cleaner	
mm	in.	Ordering Number	Item Code
450	18	FMS-18	79637
600	24	FMS600-YST	83696
750	30	FMS750-YST	83697
900	36	FMS900-YST	83698
1050	42	FMS1050-YST	83699
1200	48	FMS1200-YST	83700
1350	54	FMS1350-YST	83701
1500	60	FMS1500-YST	83702
1650	66	FMS1650-YST	83703
1800	72	FMS1800-YST	83704

Lead time: 1 working day

Replacement Tips	
Ordering Number	Item Code
ICT6 (C-Tip)	74535
RSA150 (V-Tip)	73628

Replacement Cushion	
Ordering Number	Item Code
FMSC	79699

Drop Bracket Kit	
Ordering Number	Item Code
YSTHDBK	79850

Blades Required per Cleaner Size									
mm	450	600	750	900	1050	1200	1350	1500	1800
in.	18	24	30	36	42	48	54	60	72
Blades Required	3	4	5	6	7	8	9	10	12

Authorized Distributor:

240 Macpherson Road • #02-01 • Singapore 348574
 Tel: +65-6484-1533 • Fax: +65-6484-1531 • E-mail: asiasales@flexco.com

Visit www.flexco.com for other Flexco locations and products.

©2022 Flexible Steel Lacing Company. 12/01/22.For reorder: X5054

